

## MINI SCISSOR LIFTS

# IM 4080 - IM 5080

**6.9 m**  
working height indoor

## STANDARD EQUIPMENT

- Rear wheels electric traction
- Negative electromagnetic parking brakes with electric disengagement
- Front wheels electric steering
- Manual deck extension 66 cm
- Manual emergency lowering
- Non-return valve on lifting cylinders
- AGM batteries 12V 85Ah C5
- Battery charger with automatic cut-off
- All movement alarm, horn, hour meter
- Inclinometer with motion cut-out and alarm
- Mechanical release for emergency hauling
- Solid rubber non-marking tires
- Antishearing electric protection
- Pot Hole protection
- Battery level control with low voltage protection
- Foldable guardrails
- Overload sensor
- Flashing beacon
- Control panel on the platform with capacitive buttons, proportional controls and diagnostics

## OPTIONALS

- Kit 230 V outlet on platform
- Kit for compressed air
- Kit additional flashing beacon
- Kit IMERVIEW



New ground control panel with integrated display for data retrieval and troubleshooting.



AGM batteries to ease maintenance. New disposition of hydraulic components on the lower frame which integrates forklift pockets.



Front electric steering enabling maximum precision of movements.



New design control panel in the platform with soft touch technology. It can be positioned around the platform by means of the protective roll bar.

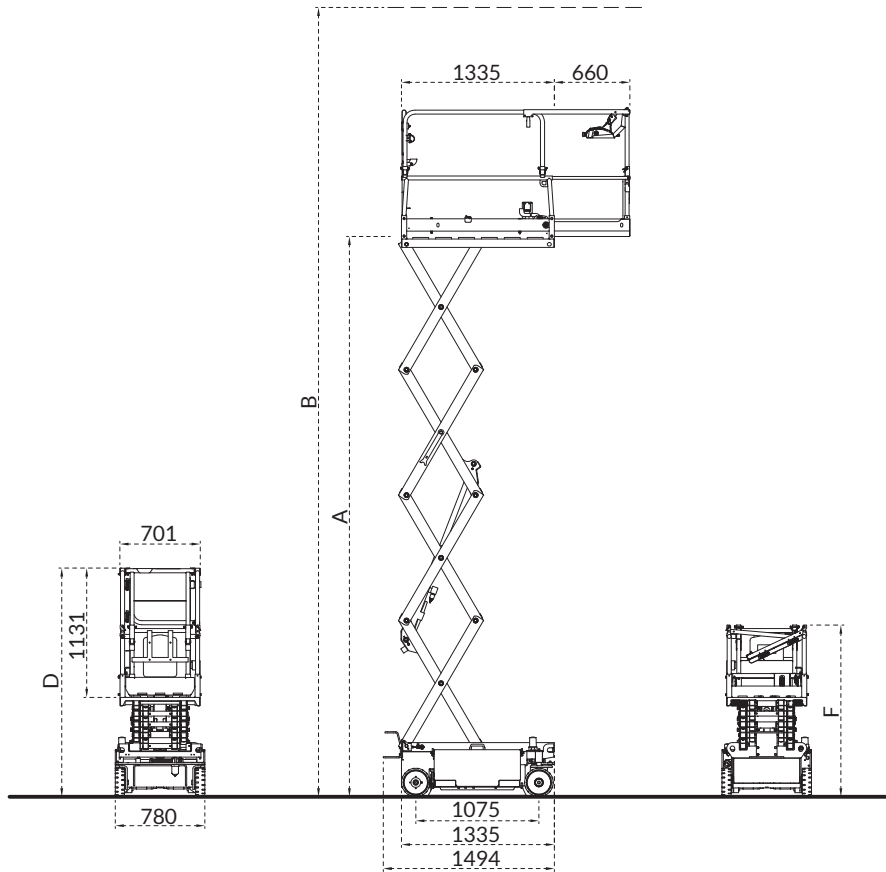

		IM 4080 UL	IM 4080 H	IM 5080 UL	IM 5080 H
Number of scissors		3	3	4	4
Platform height (A)	mm	3800 indoor 2250 outdoor	3800	4900 indoor 2450 outdoor	4900 indoor 4350 outdoor
Working height (B)	mm	5800 indoor 4250 outdoor	5800	6900 indoor 4450 outdoor	6900 indoor 6350 outdoor
Stowed height (D)	mm	1900	1900	1990	1990
Folded height (F)	mm	1410	1410	1500	1500
Length (without ladder)	mm	1490 (1335)	1490 (1335)	1490 (1335)	1490 (1335)
Width	mm	780	780	780	780
Platform extension	mm	660	660	660	660
Platform capacity	kg	230	230	230	230
Capacity on platform extension	kg	130	130	130	130
Authorized persons	n°	1	2 indoor / 1 outdoor	1	2 indoor / 1 outdoor
Traction motors	V / kW	24DC	24DC	24DC	24DC
Batteries	V/Ah	2x12/85 C5	2x12/85 C5	2x12/85 C5	2x12/85 C5
Battery charger	V/A	24V/20 Ah	24V/20 Ah	24V/20 Ah	24V/20 Ah
Oil tank capacity	l	2	2	2	2
Max. lateral/longitudinal inclination	degrees	1.50 / 3.00	1.50 / 3.00	1.50 / 2.50	1.50 / 2.50
Max driving speed	km / h	4	4	4	4
Safety speed	km / h	0.6	0.6	0.6	0.6
Gradeability	%	25	25	25	25
Internal turning radius	m	0.24	0.24	0.24	0.24
External turning radius	m	1.55	1.55	1.55	1.55
Tires dimensions	mm	250x80	250x80	250x80	250x80
Tires type		Cushion	Cushion	Cushion	Cushion
Weight	kg	700	920	750	1065